

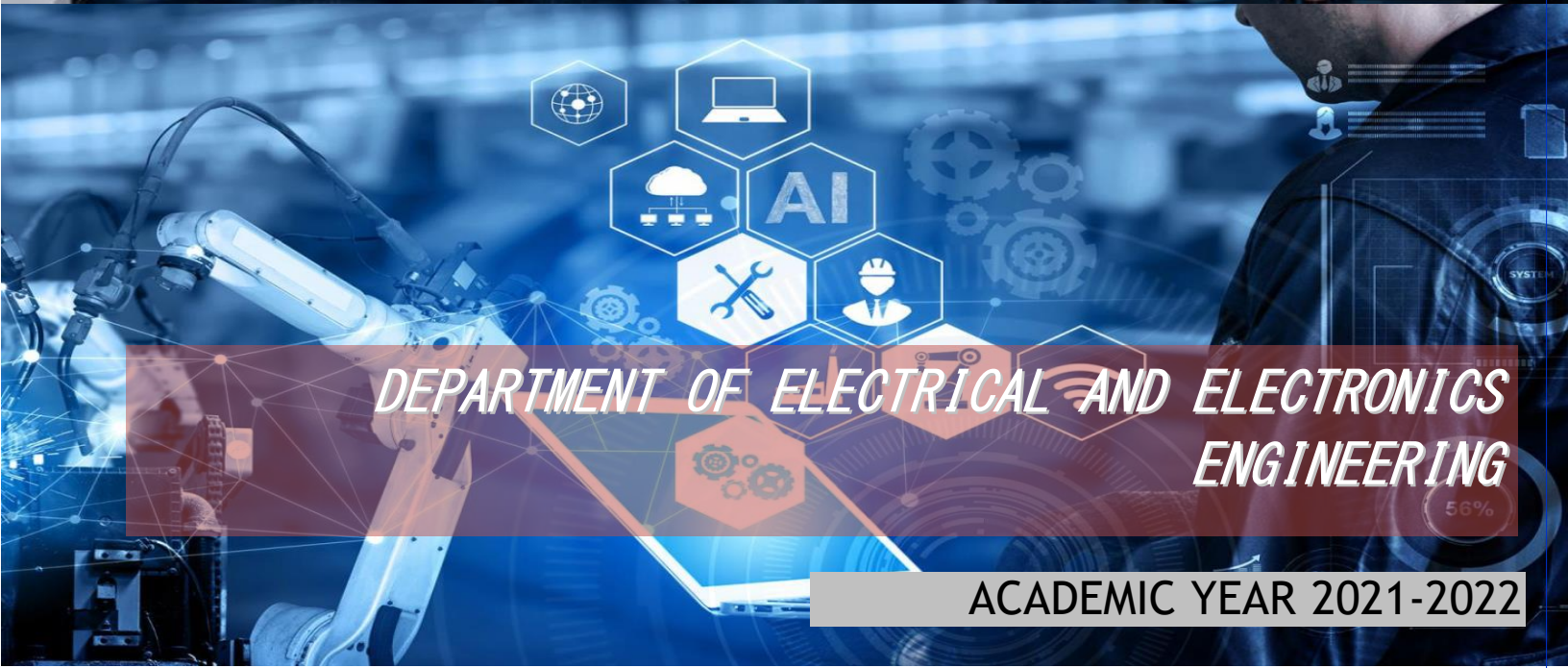

ANAND INSTITUTE OF
HIGHER TECHNOLOGY



TECH-EEE



*DEPARTMENT OF ELECTRICAL AND ELECTRONICS
ENGINEERING*

ACADEMIC YEAR 2021-2022

EDITORIAL COMMITTEE



Cheif Editor:

Dr. S. Hari Krishnan, Professor and Head/EEE

Faculty Editor:

Mr. P. Aruna, Asso/EEE

Student Editorial committee members:

- | | |
|----------------------|-----------------|
| 1. Surendhar | - IV. B.E. EEE |
| 2. Nandhini Prasad | - III. B.E. EEE |
| 3. Dhana Sagaya Jose | - IV. B.E. EEE |
| 4. Gokul | - IV. B.E. EEE |
| 5. Tajudeen | - III. B.E. EEE |
| 6. Pradeep | - II. B.E. EEE |
-

TABLE OF

Contents

03 PAPER BATTERY

05 IOT-(INTERNET OF THINGS)

07 E-BIKES

09 ENERGY SECTORS IN INDIA

12 KNOWLEDGE CORNER

14 "TESLA"- ELON MUSK

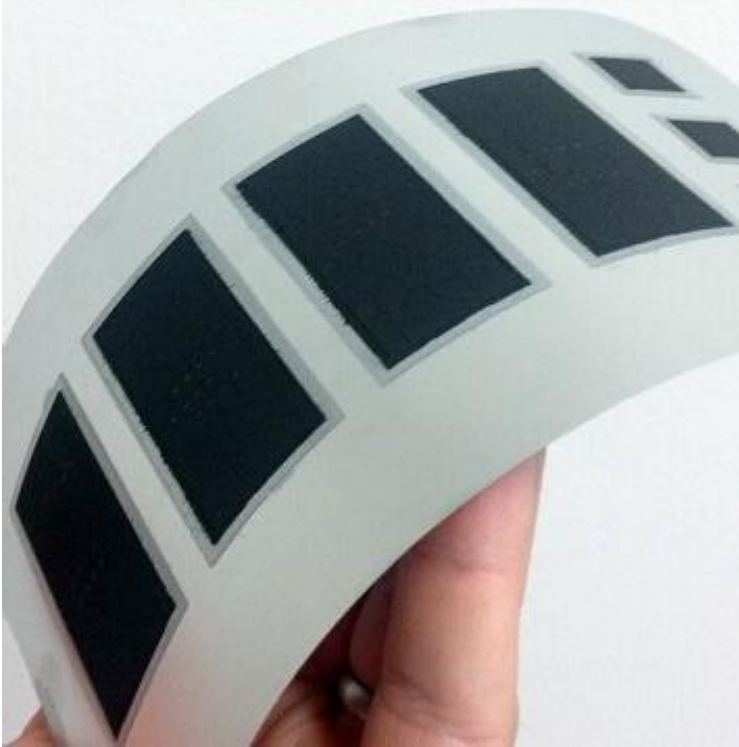
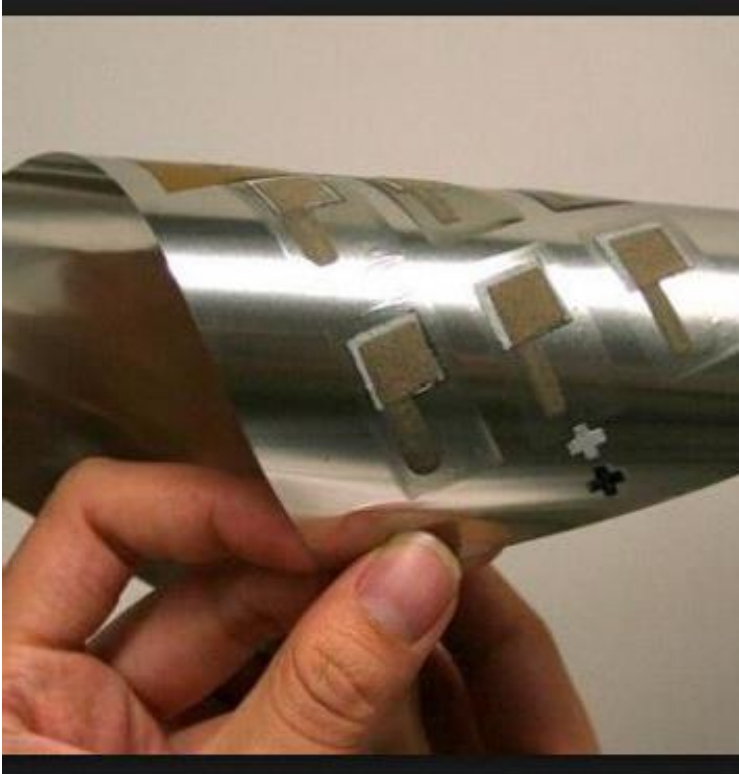

Paper Battery

This flexible and thin energy storage device can be used as a battery.

The advancement in technology developed environmentally friendly and more flexible batteries such as paper batteries.

The flexible and thin energy storage device which can be used as a battery is called as paper battery.

This paper battery can also be used as a capacitor. This battery can be produced by merging the nano tubes (made using carbon) and nano-composite paper (made using cellulose).

The paper battery consists of property of a battery - high-energy storage capacity and property of super capacitor - high-energy density and thus, produces extreme power. This combination allows the battery to provide both long-term, steady power production and bursts of energy.

Cellulose based paper is a natural abundant material, biodegradable, light, and recyclable with a well-known consolidated manufacturing process. Paper batteries may be folded, cut or shaped for different applications without any loss of integrity or efficiency. Cutting one in half halves its energy production. Stacking them multiplies power output.

What is now proved was once only imagined "

- Carbon Nanotube (CNT) used for cathode terminal
- Lithium metal (Li+) used for anode terminal
- Different types of electrolytes that include blood, urine, and sweat (which are termed as bio-electrolytes)
- Paper (Cellulose-Separator)

APPLICATIONS

There are numerous applications for paper batteries in various fields. In electronics, paper battery is typically used in mobiles, laptops, calculators, cameras, mouse, keyboard, Bluetooth devices, and so on. Similarly, in medical sciences for artificial tissues, cosmetics, drug delivery systems, and so on. In automobiles and aircraft, paper batteries are used in hybrid vehicles because of their light weight.

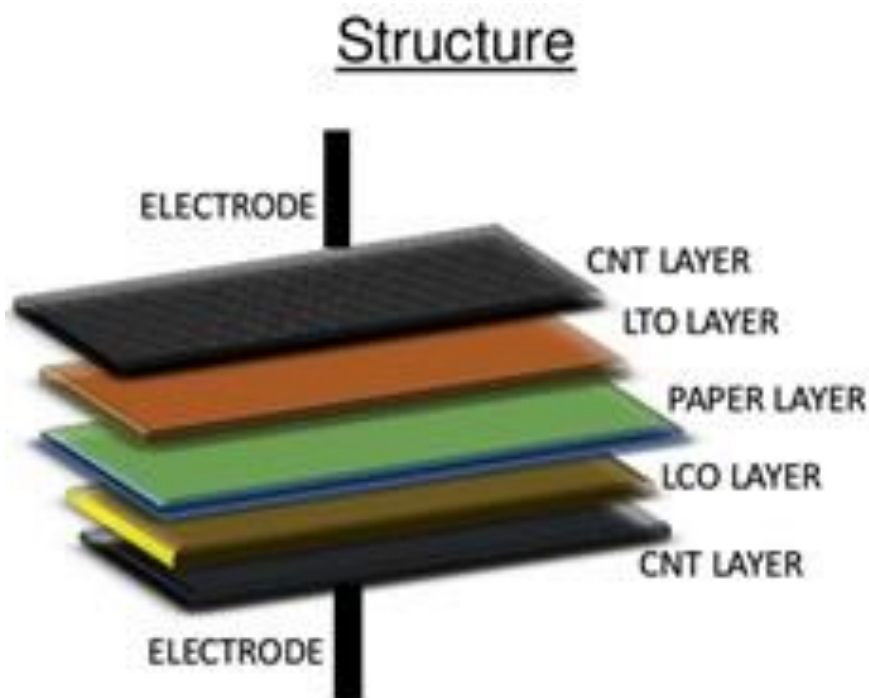

"What is now proved was once only imagined"

Internet of Things(IOT)

"The Internet of Things is removing mundane repetitive tasks or creating things that just weren't possible before, enabling more people to do more rewarding tasks and leaving the machines to do repetitive jobs."

INTRODUCTION:

The Internet of Things (IoT) is the network of physical objects—devices, instruments, vehicles, buildings and other items embedded with electronics, circuits, software, sensors and network connectivity that enables these objects to collect and exchange data. The Internet of Things allows objects to be sensed and controlled remotely across existing network infrastructure, creating opportunities for more direct integration of the physical world into computer-based systems, and resulting in improved efficiency and accuracy.

CONCEPT:

Kevin Ashton firstly proposed the concept of IoT in 1999, and he referred the IoT as uniquely identifiable connected objects with radio-frequency identification (RFID) technology. However, the exact definition of IoT is still in the forming process that is subject to the perspectives taken. IoT was generally defined as "dynamic global network infrastructure with self-configuring capabilities based on standards and communication protocols".



ARCHITECTURE OF IOT :

A critical requirement of an IoT is that the things in the network must be connected to each other. Design of IoT architecture involves many factors such as networking, communication, processes etc. In designing the architecture of IoT, the extensibility, scalability, and operability among devices should be taken into consideration. Due to the fact that things may move and need to interact with others in real-time mode, IoT architecture should be adaptive to make devices interact with other dynamically and support communication amongst them.

There

are four layers with distinguished functionalities provide the interoperability among the devices in multiple ways .They are:

- 1)Sensing layer is integrated with all available objects (things) to sense their status.
- 2) Network layer is the infrastructure to support the wireless or wired onnections among things.
- 3)Service layer is to create and manage services required by users or applications.
- 4) Interfaces layer consists of the interaction methods with users or applications.

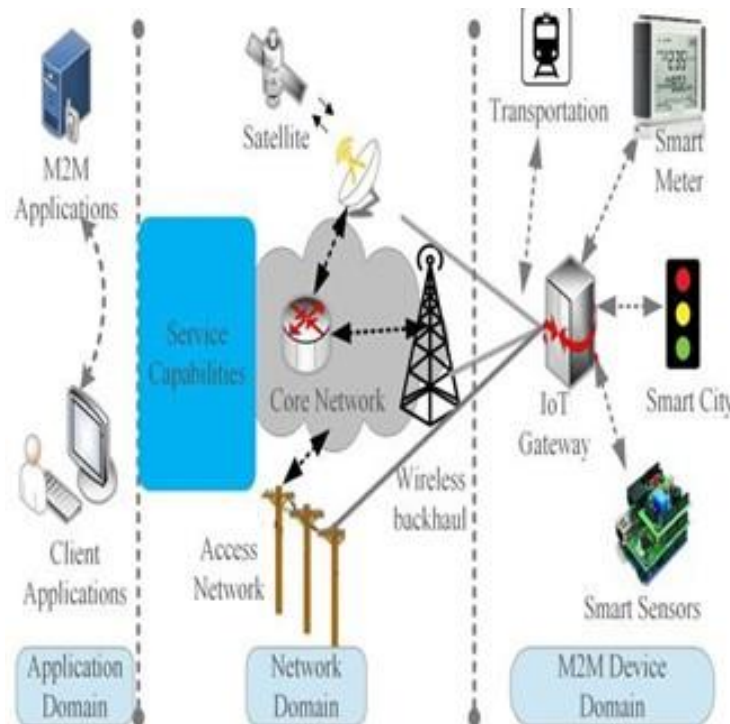

E-Bikes

*"FOUR WHEELS MOVES THE BODY
TWO NWHEELS MOVES THE SOUL"*

INTRODUCTION :

Electric motorcycles and scooters are plugin electric vehicles. The electricity is stored on board in a rechargeable battery, which drives one or more electric motors. Electric scooters have a step-through frame. An electric vehicle may be powered through a collector system by electricity from off-vehicle sources, or may be self-contained with a battery, solar panels or an electric generator to convert fuel to electricity.

CURRENT MANUFACTURERS :

Electric motorcycle manufacturers include

- Čezeta
- Victory
- Mahindra
- Zero Motorcycles
- Lightning Motorcycle
- Energica Motor Company
- KTM and Ampere Vehicle.



*"Every day is a good day
for a ride "*

POWER SOURCE

Most electric motorcycles and scooters as of May 2019 are powered by rechargeable lithium ion batteries, though some early models used nickel-metal hydride batteries. All electric scooters and motorcycles provide for recharging by plugging into ordinary wall outlets, usually taking about eight hours to recharge (i.e. overnight). Some manufacturers have designed in, included, or offer as an accessory, the high-power CHAdeMO level 2 charger, which can charge the batteries upto 95% in an hour.

WHY e-BIKES INSTEAD OF GASOLINE?

In performance, Electric machines have better 0 to 60 acceleration, since they develop full torque immediately, and without a clutch the torque is instantly available. Electric motorcycles and scooters suffer considerable disadvantage in range, since batteries cannot store as much energy as a tank of gas. Electric scooters and motorcycles need very little maintenance as compared to gasoline bikes. At between one and two cents per mile electric machines enjoy an enormous fuel cost advantage. Even with special equipment, charging a battery takes significantly longer than filling a gas tank, which can make electric vehicles less flexible than their gasoline counterparts.



Power Sector is the Largest Consumer of Coal in India

Share of coal consumption in 2017-18 (%)



Source: Ministry of Coal, Central Statistics Office

© BCL 2019. ALL RIGHTS RESERVED.

Energy Sectors in India

How many energy sectors in India and Tamilnadu?:

The power sector in india has undergone significant progress after Independence. hen India became Independence in 1947, the country had a power generating capacity of 1,362MW. Hydro power and coal based thermal power have been the main sources of generating electricity. We will see in now a days how many energy sectors available in India, and how many power will be produced in now a days.

- Central Sector - 90,177MW -25.0%
- State Sector -102,818 -28.5%
- Private Sector - 167,462 -46.5%

Total power produced in India is 3,60,456 Tamil Nadu has 6.49% of total Thermal power station located in India. Tamil Nadu produce 10,075,10MW power by coal based power plant. Tamil Nadu has 4 major thermal power stations.

1. Tuticorin
2. Neiyeli
3. Atthipattu
4. Ennore



Power Plant	MW percentage in 2017	MW percentage in 2018
1.coal	38%	64%
2.Gas	23%	7.21%
3.Nuclear	10%	6%
4.Rennewable	25%	21%
5.oil	4%	1.8%

Renewable Energy:

The major Renewable Energy Source are,

1. Solar power
2. Wind power
3. Hydro power
4. Geo thermal power

Solar power:

Top 5 Solar power plants in India:

1. Pavagada Solar Park, Karnataka
2. Kurnool Ultra Mega Solar Park, Andhra Pradesh
3. Kamuthi Solar Power Project, Tamil Nadu
4. Bhadla Solar Park, Rajasthan
5. Charanka Solar Park, Gujarat



Hydro electric power plant:

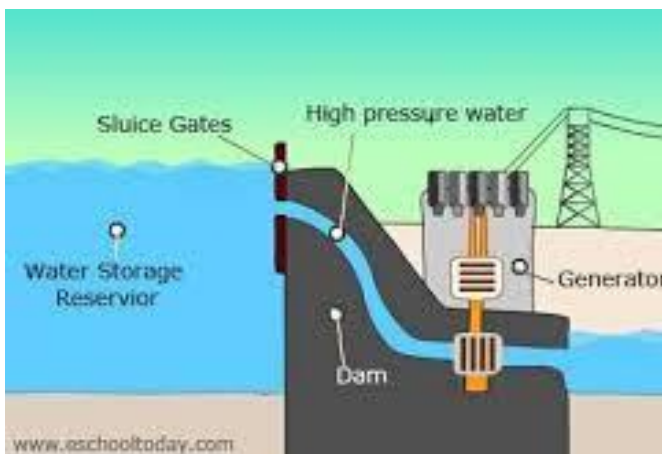

Name	Operator	Location	Configuration
Tehri Dam (3 Stages)	THDC Limited, Uttarakhand	Uttarakhand	2400 MW
Koyna Hydroelectric Project (4 Stages)	MAHAGENCO, Maharashtra State Power Generation Co Ltd.	Maharashtra	1960 MW
Srisaillam	APGENCO	Andhra Pradesh	1670 MW
Nathpa Jhakri (6 Turbines x 25 MW)	Satluj Jal Vidyut Nigam	Himachal Pradesh	1500 MW

Hydro Electric Power Generation is maximum at 9800 MW. J&K and Uttarakhand have installed capacity of 3500 MW and 3800 MW respectively. This two states are generated maximum number of Hydro electric power.

Electric power transmission and distribution:

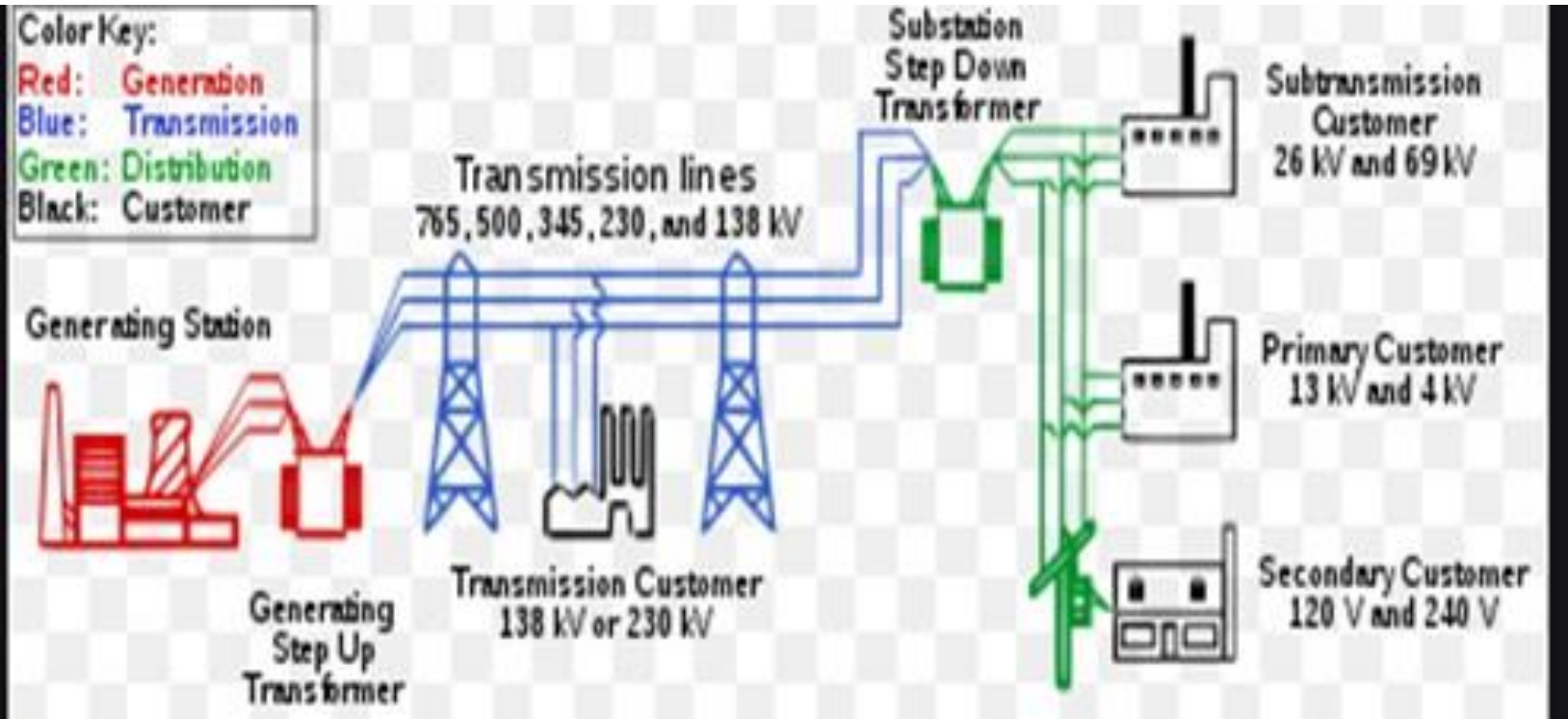

In India many of the Electric power can be transmitted , and distributed by Transmission lines. Most transmission lines are high-voltage three-phase alternating current (AC), although single phase AC is sometimes used in railway electrification systems. High-voltage direct-current (HVDC) technology is used for greater efficiency over very long distances (typically hundreds of miles). HVDC technology is also used in submarine power cables (typically longer than 30 miles (50 km)

Electricity generation, transmission, and distribution

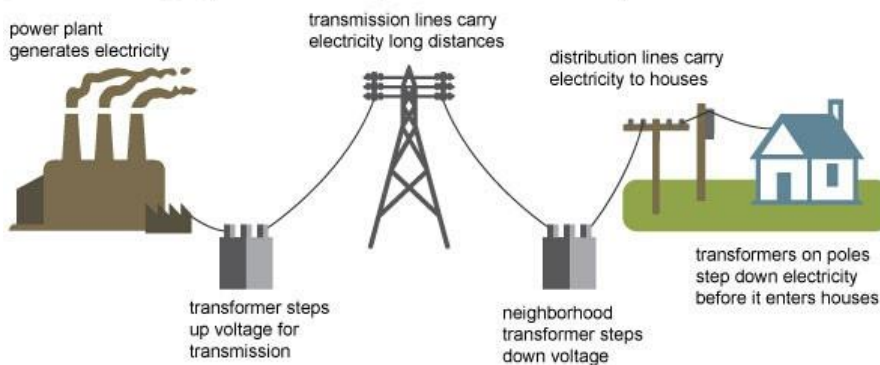

Source: Adapted from National Energy Education Development Project (public domain)

KNOWLEDGE CORNER



ELECTRICAL
ENGINEERING PORTAL

Electrical Engineering Portal (EEP)

The Electrical Engineering Portal (EEP) is a great resource focused on the power and energy field. The portal links to some great information and tools that can be useful to students learning about the generation, transmission, and distribution of electrical power.



T&d WORLD:



T&D World's mission is to provide utility executives, managers, engineers, supervisors, operators and linemen with must-read information on the design, engineering, construction, operation and maintenance of the electric power-delivery system. This includes an in-depth understanding of transmission, distribution, substations, automation and power flow control. T&D World provides utilities with the insights and technologies to integrate distributed energy resources into the grid.



ALL ABOUT CIRCUITS:

All About Circuits is known and respected for our accurate, engaging, high-quality content. We publish a wide variety of articles that provide educational resources for teachers and students, practical guidance for designers, and inspiration for electronics enthusiasts of all kinds.

EVERY CIRCUITS:

This Service is owned and operated by MuseMaze, Inc. we are a company incorporated in California and our principal place of business is located at San Jose, California

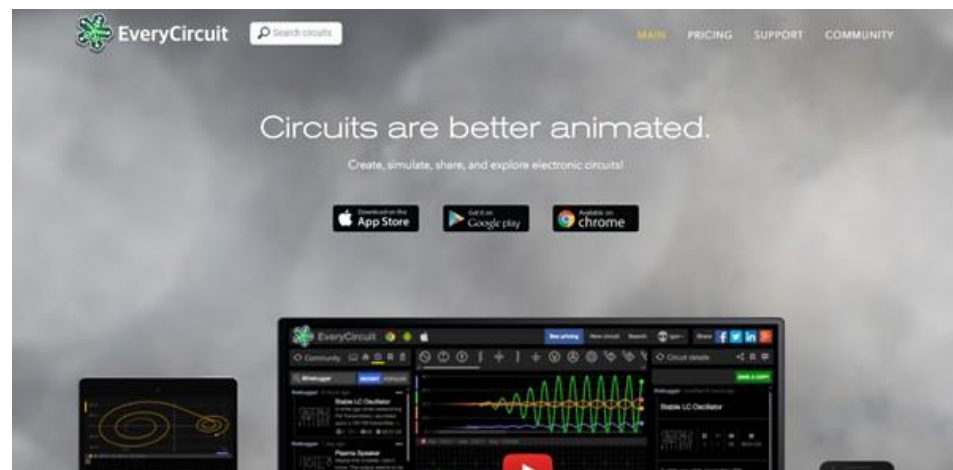

"Electricity can transform people's lives, not just economically but also socially. "

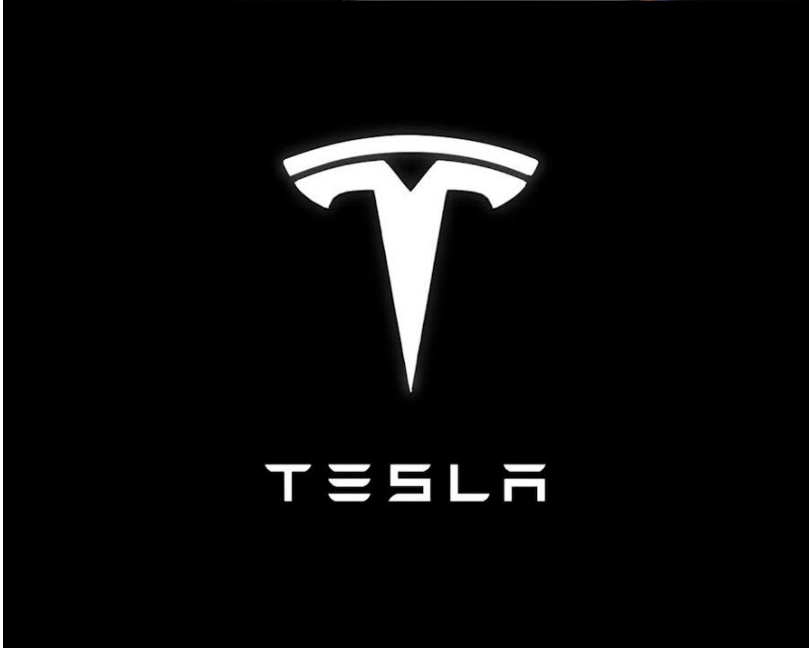

"The cars we drive say a lot about us."

"TESLA"- ELONMUSK

"Tesla's mission is to accelerate the world's transition to sustainable energy."

Tesla was founded in 2003 by a group of engineers who wanted to prove that people didn't need to compromise to drive electric – that electric vehicles can be better, quicker and more fun to drive than gasoline cars. Today, Tesla builds not only all-electric vehicles but also infinitely scalable clean energy generation and storage products. Tesla believes the faster the world stops relying on fossil fuels and moves towards a zero-emission future, the better.

Launched in 2008, the Roadster unveiled Tesla's cutting-edge battery technology and electric powertrain. From there, Tesla designed the world's first ever premium all-electric sedan from the ground up - Model S - which has become the best car in its class in every category.

Combining safety, performance, and efficiency, Model S has reset the world's expectations for the car of the 21st century with the longest range of any electric vehicle, over-the-air software updates that make it better over time, and a record 0-60 mph acceleration time of 2.28 seconds as measured by Motor Trend.

And this is just the beginning. With Tesla building its most affordable car yet, Tesla continues to make products accessible and affordable to more and more people, ultimately accelerating the advent of clean transport and clean energy production.

The Magic Model-S



"Increasing performance while decreasing value"

The Tesla Model S comes standard with two electric motors and a 100-kilowatt-hours lithium-ion battery pack. All variants of the car have insanely quick acceleration. The Long Range Plus can accelerate from zero to 60 mph in 3.7 seconds. The Model S Performance can make the same sprint in 2.4 seconds.

Handling and Braking

You can count on the all-wheel-drive Model S for composed handling around turns and great road grip. While some critics write that steering feels vague, others note that it provides a good amount of feedback. The Model S' ride is on the firmer side, but it still feels comfortable.